



Product Features

- **Energy Efficient:** Significantly reduces power consumption.
- **Low Temperature Rise:** Lowers coil temperature by over 50% to extend lifespan.
- **Stable Performance:** Built-in temperature compensation for reliable operation.
- **Circuit Protection:** Integrated overcurrent fuse for enhanced safety.
- **Flexible Settings:** Adjustable holding current and PWM duty cycle.
- **Fast Response:** Suitable for high-frequency switching applications.
- **Certified Quality:** RoHS and CE compliant.



Product Description

Compared with traditional constant-voltage driving methods, the PAB Series effectively reduces coil temperature rise, minimizing aging and component wear caused by heat. This helps extend solenoid valve lifespan and reduce maintenance frequency.

With lower power consumption, the PAB Series improves overall energy efficiency while delivering stable and reliable performance. Its strong anti-interference capability also makes it suitable for various industrial environments, especially applications requiring long operating hours or high-temperature operation.

Product Applications

- Solenoid valves
- Magnetic Contactor
- Electronic locks
- Electromagnets
- Relays



Product Functions

- Operating Voltage Range: 12/24VDC (-10% / +10%)
- Pulse Output Current: Max. 1200mA
- Continuous Output Current: Max. 500mA
- Adjustable Energy-Saving Rate
- Adjustable Energy-Saving Activation Time: 300~999ms (+/-10%)
- Low Noise, No Magnetic Loss, Reduced Coil Temperature
- Operating Temperature: -20°C ~ 60°C

Electrical Parameters

MIT A Type (24V, 0~60°C)

Parameter		Min	Max	Unit
Operating Voltage	12V	10.8	13.2	V
	24V	21.6	26.4	V
Maximum Pulse Current		0	1.2	A
Maximum Continuous Current		0	0.2(24V), 0.4(12V)	A
Allowable Coil Resistance		full range		Ohm
Switching Time		300	999	mS
Holding Power	5W	4500	5500	mW
	6W	5400	6600	
	7W	6300	7700	
	8W	7200	8800	
Operating Frequency		500		Hz
Duty Cycle		0~80		%
ESD Protection		4000		V
Operating Temperature		-20	60	°C

Note 1: If the above specifications do not meet your requirements, customized solutions can be developed according to your application needs.

Note 2: A fuse is installed on the power input side to protect against surge voltage and excessive current conditions.

Note 3: During engineering testing, a VR version is available to adjust the duty cycle 40~60% power saving ratio: (CW = current decrease), (CCW = current increase).

Note 4: Incorrect operation may cause malfunction/ damage, e.g., connecting a 24V supply to a 12V coil will result in burnout.



Energy-Saving Mode Main Function

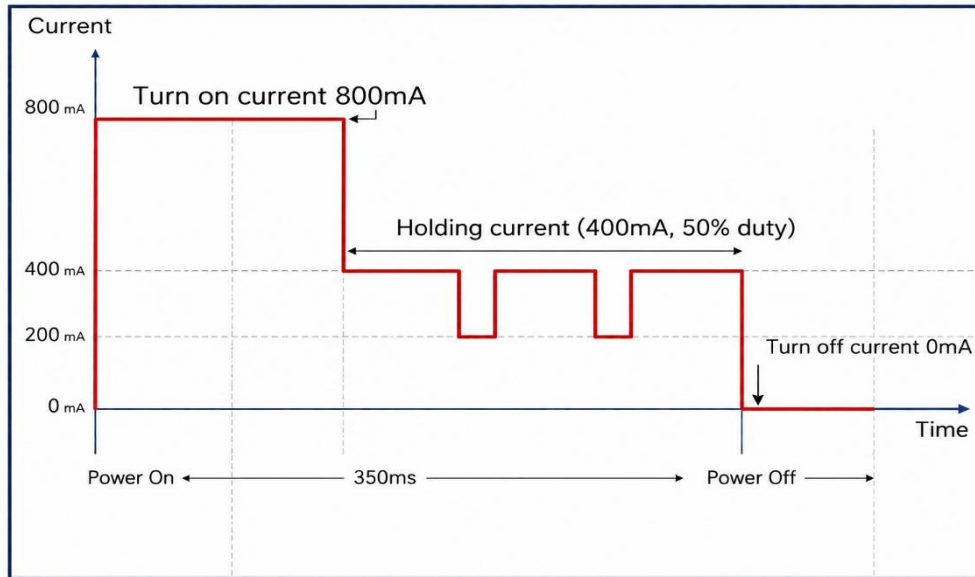

Topology Example (50% duty)

Circuit Diagram Description

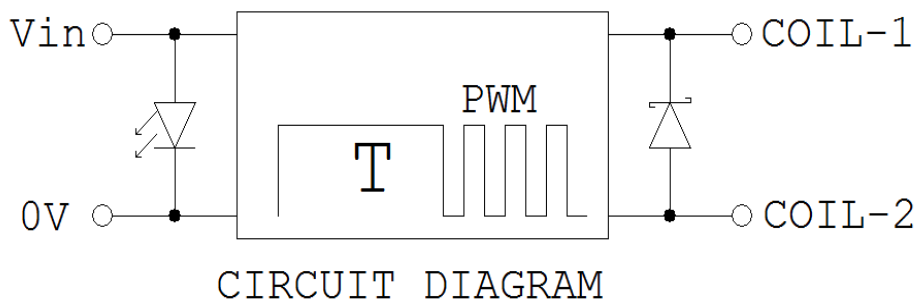

CIRCUIT DIAGRAM

Surge Protection, LED x 1(power on)

Energy-Saving Control Box Dimensions & 3D View

Unit: mm (DIN43650 A)

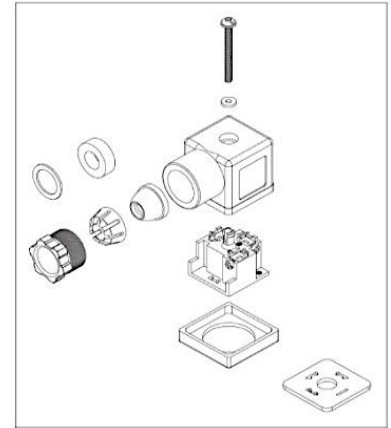
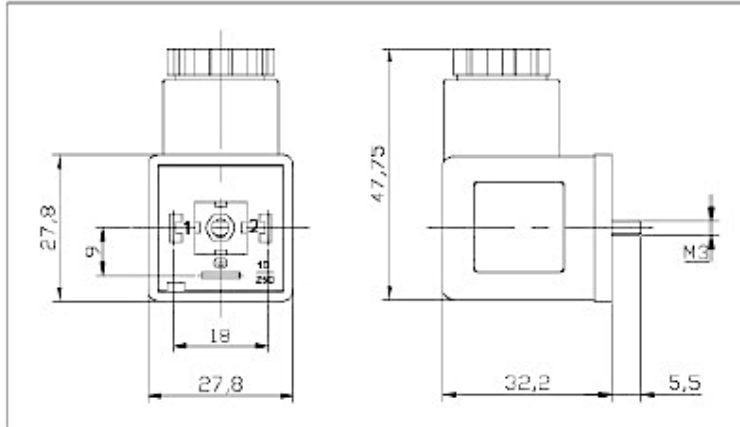

Ordering Information

PAB-VV-WW-SS-PWM

VV: Input Voltage range [unit:V]

VV value	24
Vcc min [V]	21.6
Vcc max [V]	26.4

WW: Duty cycle [%]

WW value	30	40	50
Duty Cycle [%]	30	40	50

SS: Translate Time (second stage time) [unit:ms]

SS value	35	50	99
Delay time	350ms	500ms	999ms



User Notice

Product specifications shown herein are subject to change without prior notice. Magnetic Integrated Technology Co., Ltd. and its representatives assume no responsibility for errors or inaccuracies contained in this document. Buyers are solely responsible for the selection, application, and use of MIT products. The information provided in this document is intended solely for product description purposes and does not grant any intellectual property rights, either express or implied. Except as specified in MIT's terms and conditions of sale, MIT assumes no liability related to the sale and/or use of its products, including any implied warranties of merchantability, fitness for a particular purpose, or non-infringement of intellectual property rights. The products described herein are not designed for medical, life-saving, or life-support applications. Customers using or selling these products for such applications do so at their own risk and agree to fully indemnify MIT against any resulting damages.

Copyright & Disclaimer

No part of this document may be reproduced in any form without prior written permission from Magnetic Integrated Technology Co., Ltd. Copyright © 2026 Magnetic Integrated Technology Co., Ltd. All rights reserved. MIT reserves the right to modify the information contained in this document at any time without prior notice. MIT products are intended solely for industrial and general commercial applications and must not be used in medical life-support equipment or systems.