

MEMS Pressure Sensor Preliminary Datasheet

1. General Introduction

M0104 is an MEMS Process & Gauge type MEMS pressure sensor especially designed for applications requiring pressure measurement from -1 bar to 10 bar. The pressure sensor is based on the industry-recognized piezo-resistive technology featuring long-term stability and EMC robustness.

2. Features

- ◆ Constant current or constant voltage drive
- ◆ MEMS process technology
- ◆ Gauge type sensor
- ◆ Operation range : -1 bar ~ 10 bar

3. Applications

- ◆ Blood pressure measurement
- ◆ Industrial control
- ◆ Pressure gauge

4. Maximum Rating

Parameter	Symbol	Condition	Min.	Typ.	Max.	Unit
Max. Pressure Range			-1	10	15	bar

5. Specifications

Parameter	Symbol	Condition	Min.	Typ.	Max.	Unit
Operation Voltage	Vin		—	5	10	V
Operation Current	I0		—	1	2	mA
Bridge Impedance			4.5	5	5.5	kΩ
Operating Pressure			-1		10	bar
Full Scale Span	FS	Vin=5V	40	50	70	mV
Offset		Vin=5V	-15	0	15	mV
Linearity			-0.3	±0.15	+0.3	%FS
TC Span		Constant voltage	-0.17	-0.22	-0.27	%FS/°C
		Constant current	-0.08	±0.02	+0.08	%FS/°C
TC Offset			-0.08	-0.05	+0.08	%FS/°C
Burst Pressure			—	—	3X	Rated FS
Temperature Range			-40	25	+85	°C
Storage Temperature			-40		+125	°C

6 · Schematic Diagram

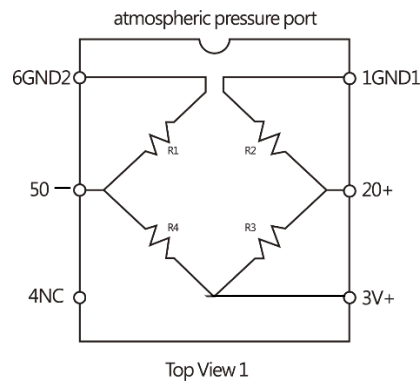
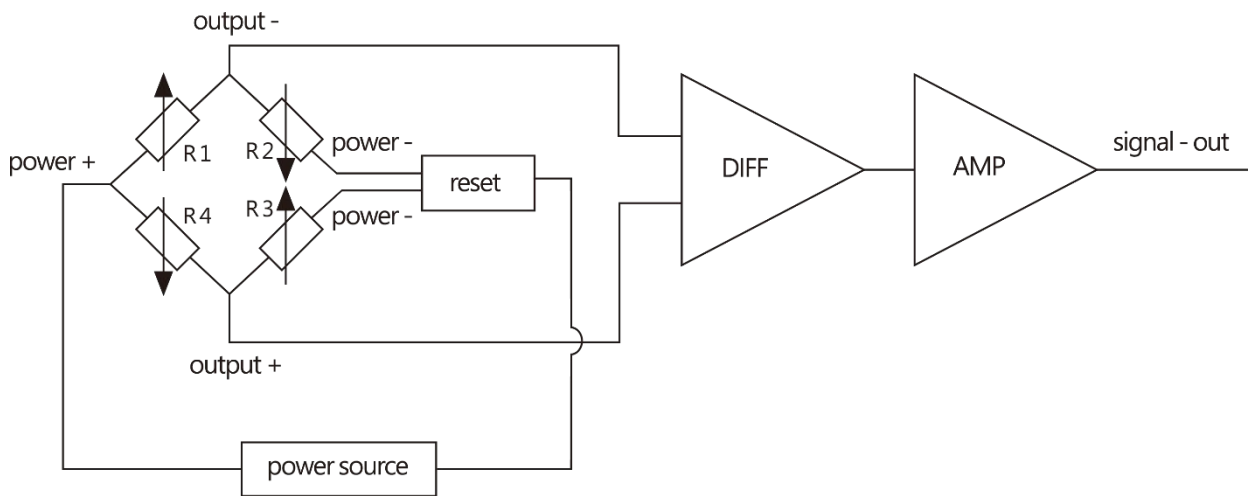

7. Backside Marking Information

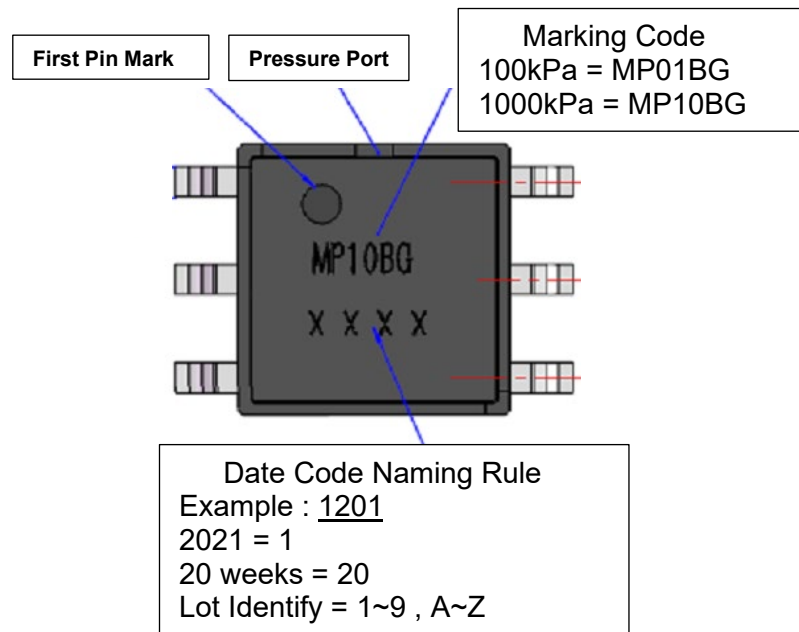

8 · No-Linearity and Temperature Effect

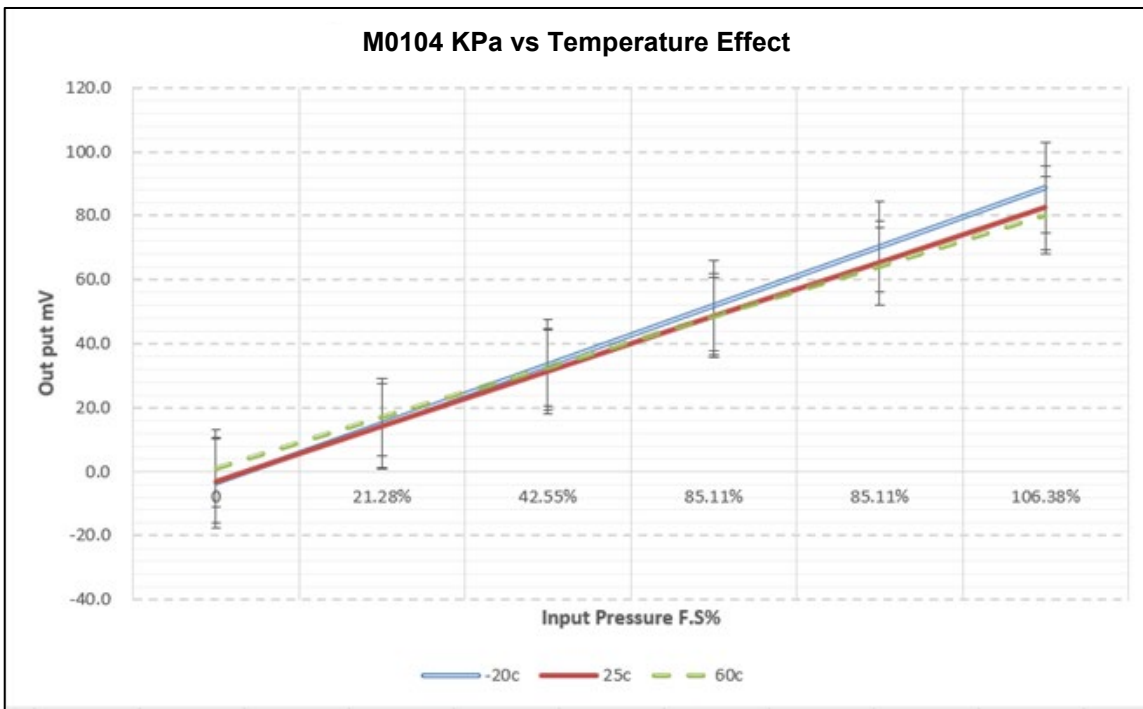

9. Negative Output Linearity Diagram

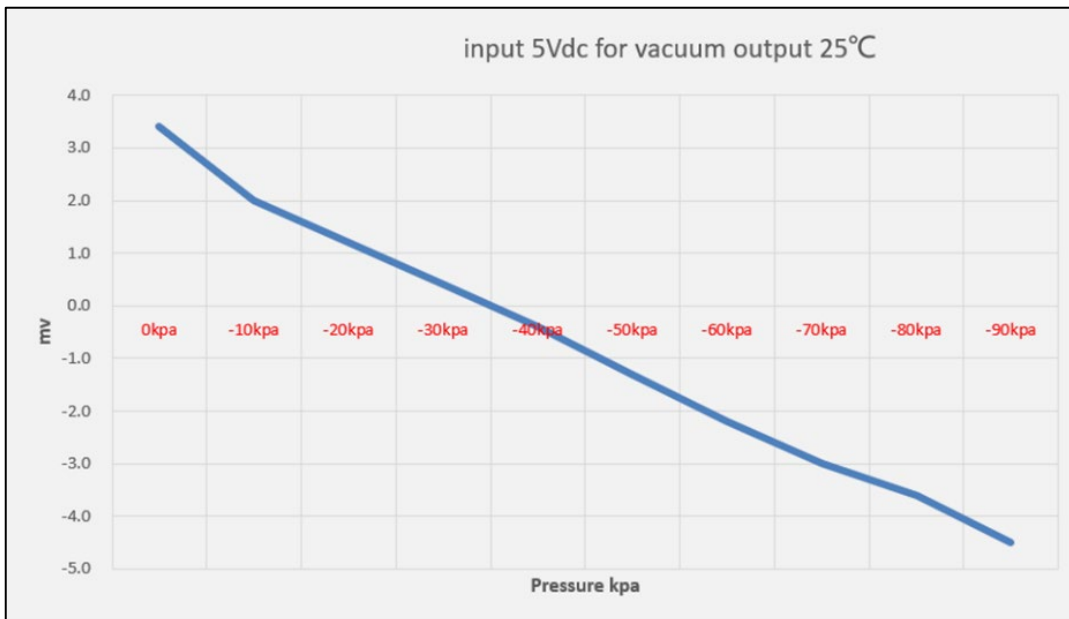

10. Pin Layout and Definition

Unit : mm

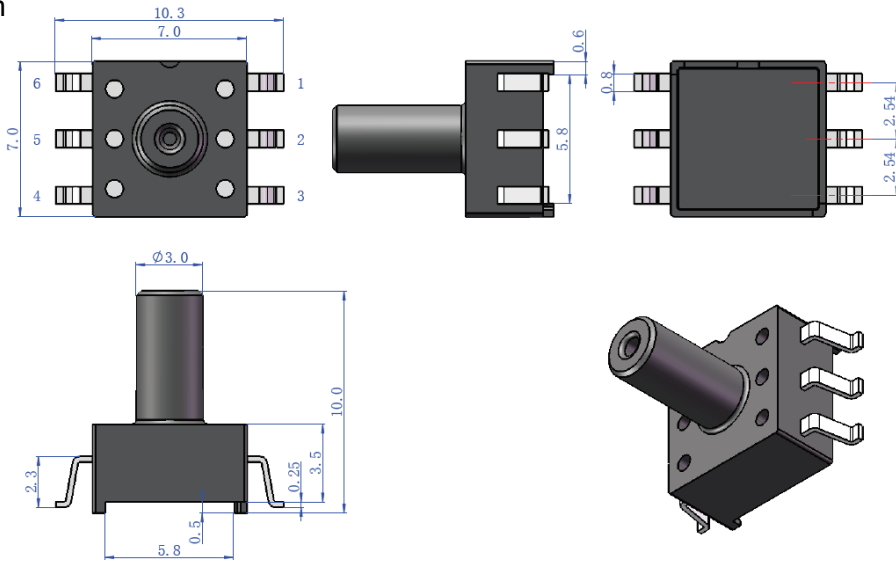

11. Packing Instructions

- ◆ 500pcs per 13" reel & dry packing
- ◆ Vibration-proof packing

ITEM	W	A0	B0	K0	R1	P	F	E	D0	D1	P0	P2	T	13"	
DIM	24.00	7.35	10.80	10.40	~	12.00	11.50	1.75	1.50	~	4.00	2.00	0.50	length/reel	pcs/reel
TOLE	+0.30	+0.15	+0.15	+0.10		+0.10	+0.10	+0.10	+0.10		+0.10	+0.15	+0.05	6.5M	500 pcs
	-0.30	-0.15	-0.15	-0.10		-0.10	-0.10	-0.10	-0.10		-0.10	-0.15	-0.05		

Unit : mm

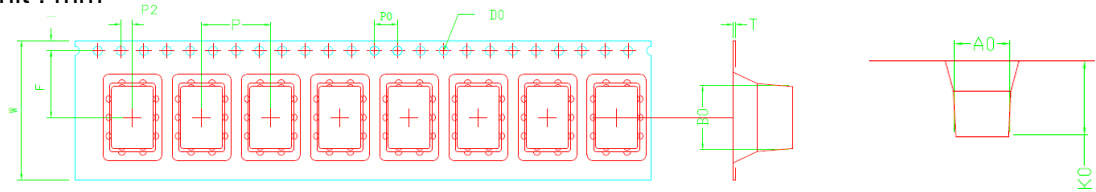

Copy Rights and Disclaimer

1. This document may not be reproduced or duplicated, in any form, in whole or in part without prior written consent of MIT . Copyrights © 2021, MIT-Magnetic Integrated Technology Incorporated.
2. MIT-Magnetic Integrated Technology reserves the right to make changes to the information published in this document at anytime without notice.
3. MIT's products are limited for use in normal commercial applications. MIT's products are not to be used in any device or system, including but not limited to medical life support equipment and system.